

BANCO AJUSTABLE

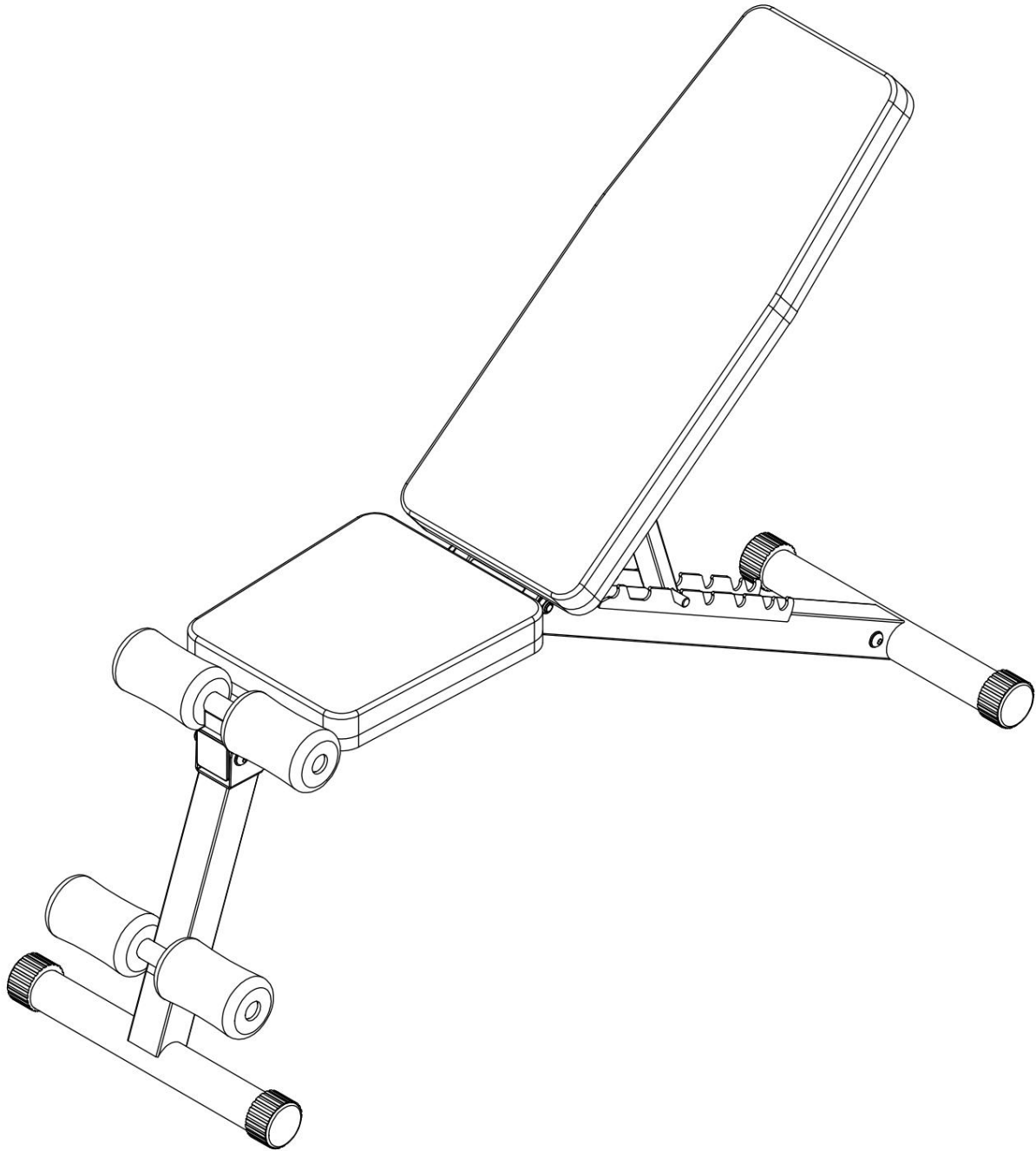

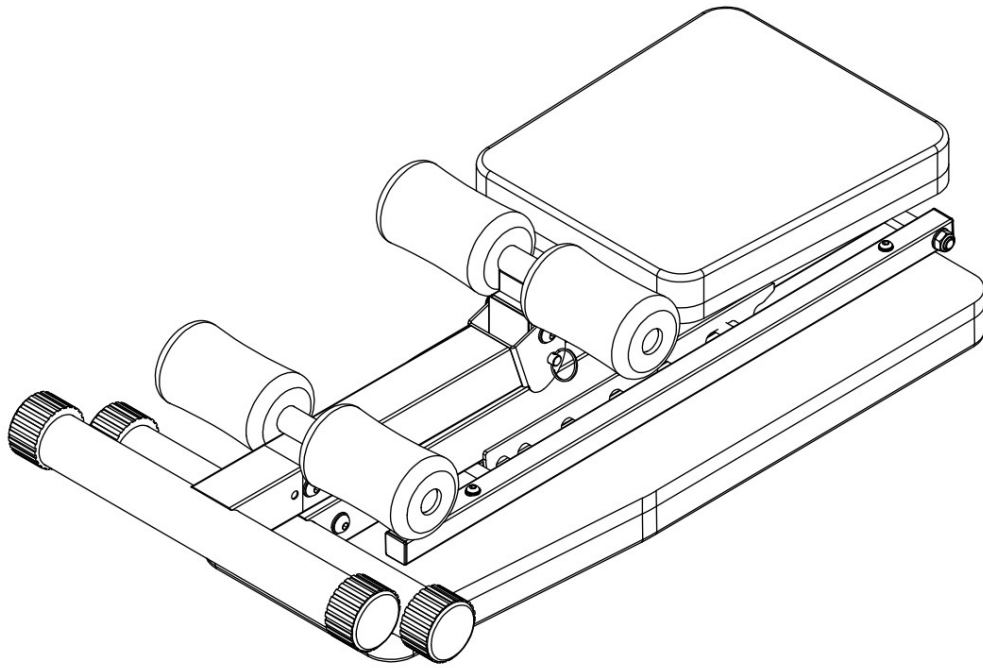

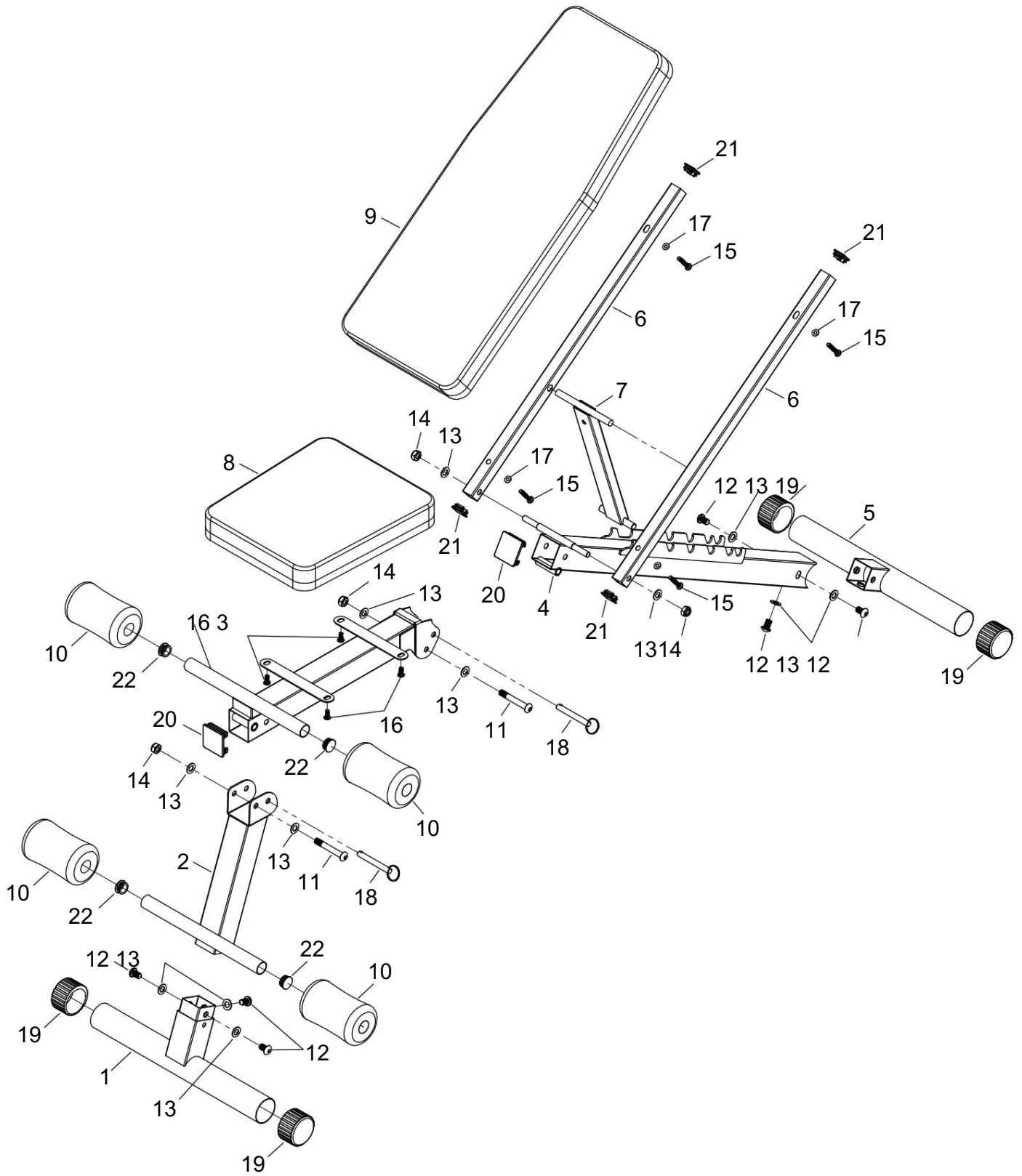





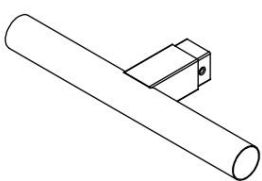
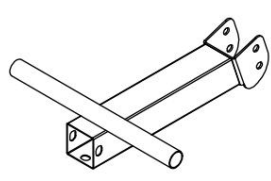
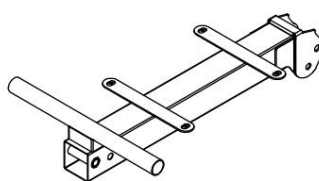
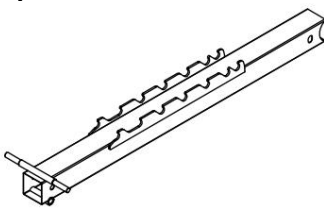
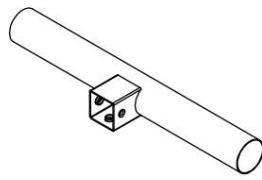
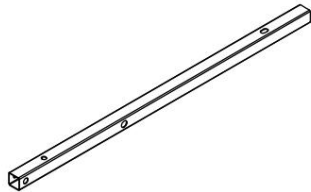
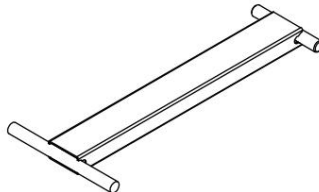
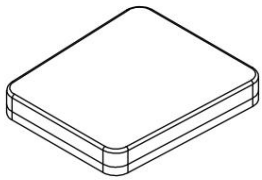
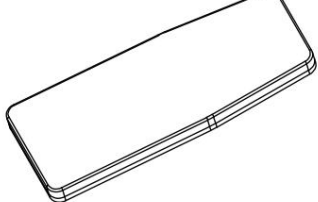







DIBUJO DESCUBIERTO





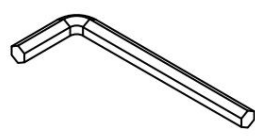

LISTA DE PIEZAS

<p>1</p>  <p>Tubo del pie delantero 1 pieza</p>	<p>2 Preinstalado</p>  <p>Soporte frontal 1 pieza</p>	<p>3 Preinstalado</p>  <p>Marco del asiento 1 pieza</p>	<p>4 Preinstalado</p>  <p>Marco principal 1 pieza</p>
<p>5</p>  <p>Tubo del pie trasero 1 pieza</p>	<p>6 Preinstalado</p>  <p>Tubo de respaldo 2 piezas</p>	<p>7 Preinstalado</p>  <p>Soporte para la espalda 1 pieza</p>	<p>8 Preinstalado</p>  <p>Cojín de asiento 1 pieza</p>
<p>9 Preinstalado</p>  <p>Respaldo 1 pieza</p>	<p>10</p>  <p>Espuma 4 piezas</p>	<p>11 Preinstalado</p>  <p>Pernos de cabeza hueca hexagonal M10*70 2 piezas</p>	<p>12</p>  <p>Pernos de cabeza hueca hexagonal M10*15 6 piezas</p>
<p>13 6 piezas preinstaladas</p>  <p>Arandela plana M10 12 piezas</p>	<p>14 Preinstalado</p>  <p>Tuerca de bloqueo M10 4 piezas</p>	<p>15 Preinstalado</p>  <p>Pernos de cabeza hueca hexagonal M6*40 4 piezas</p>	<p>16 Preinstalado</p>  <p>Pernos de cabeza hueca hexagonal M6*12 4 piezas</p>
<p>17 Preinstalado</p>  <p>Arandela plana M6 4 piezas</p>	<p>18</p>  <p>Pasador de anillo 2 piezas</p>	<p>19 Preinstalado</p>  <p>Tapa de extremo redonda de 50 mm 4 piezas</p>	<p>20 Preinstalado</p>  <p>Tapón de extremo cuadrado de 50 mm 2 piezas</p>
<p>21 Preinstalado</p>  <p>Tapón de extremo cuadrado de 25 mm 4 piezas</p>	<p>22 Preinstalado</p>  <p>Tapón de extremo redondo de 25 mm 4 piezas</p>	<p>23</p>  <p>Herramienta 1 pieza</p>	

Lista de Piezas

N° de pieza	Nombre de la pieza	Cantidad
1	Tubo de apoyo delantero	1
2	Soporte delantero	1
3	Estructura del asiento	1
4	Estructura principal	1
5	Tubo de apoyo trasero	1
6	Tubo del respaldo	2
7	Soporte del respaldo	1
8	Cojín del asiento	1
9	Respaldo	1
10	Rodillo de espuma	4
11	Tornillo Allen M10x70	2
12	Tornillo Allen M10x15	6
13	Arandela plana M10	12
14	Tuerca autofrenante M10	4
15	Tornillo Allen M6x40	4
16	Tornillo Allen M6x12	4
17	Arandela plana M6	4
18	Pasador con anilla	2
19	Tapón redondo 50 mm	4
20	Tapón cuadrado 50 mm	2
21	Tapón cuadrado 25 mm	4
22	Tapón redondo 25 mm	4
23	Herramienta (llave Allen)	1

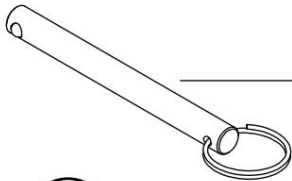
BOLSA DE FERRETERÍA

	12# Pernos de cabeza hueca hexagonal M10*15	6 piezas
	Arandela plana M10 n.º 13	6 piezas
	Pasador de anillo n.º 18	2 piezas
	Herramienta n.º 23	1 pieza

INSTRUCCIONES DE MONTAJE

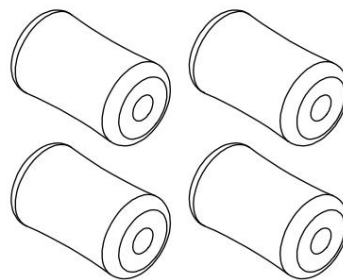
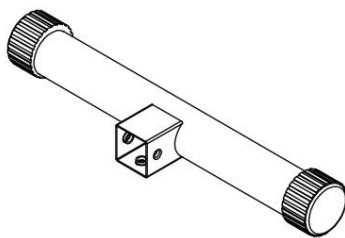
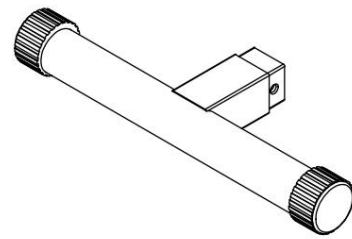
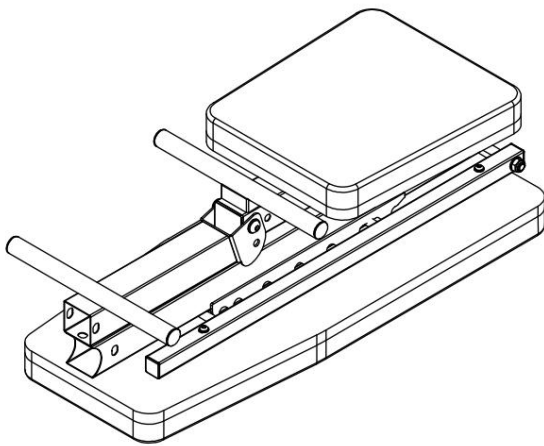

INSTRUCCIONES DE MONTAJE

PASO 1:

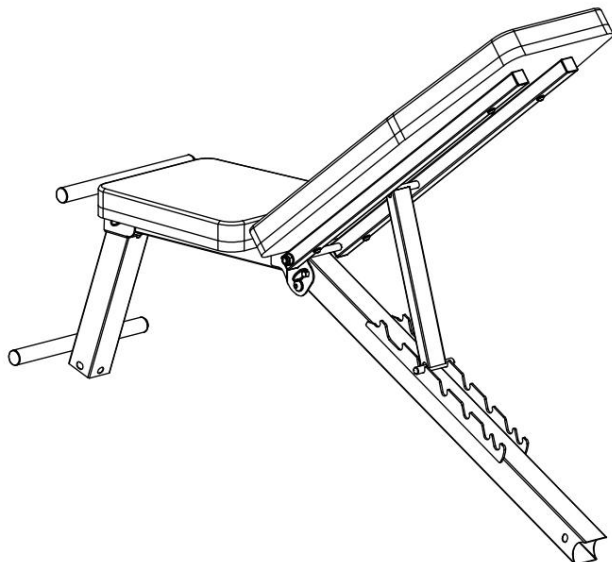
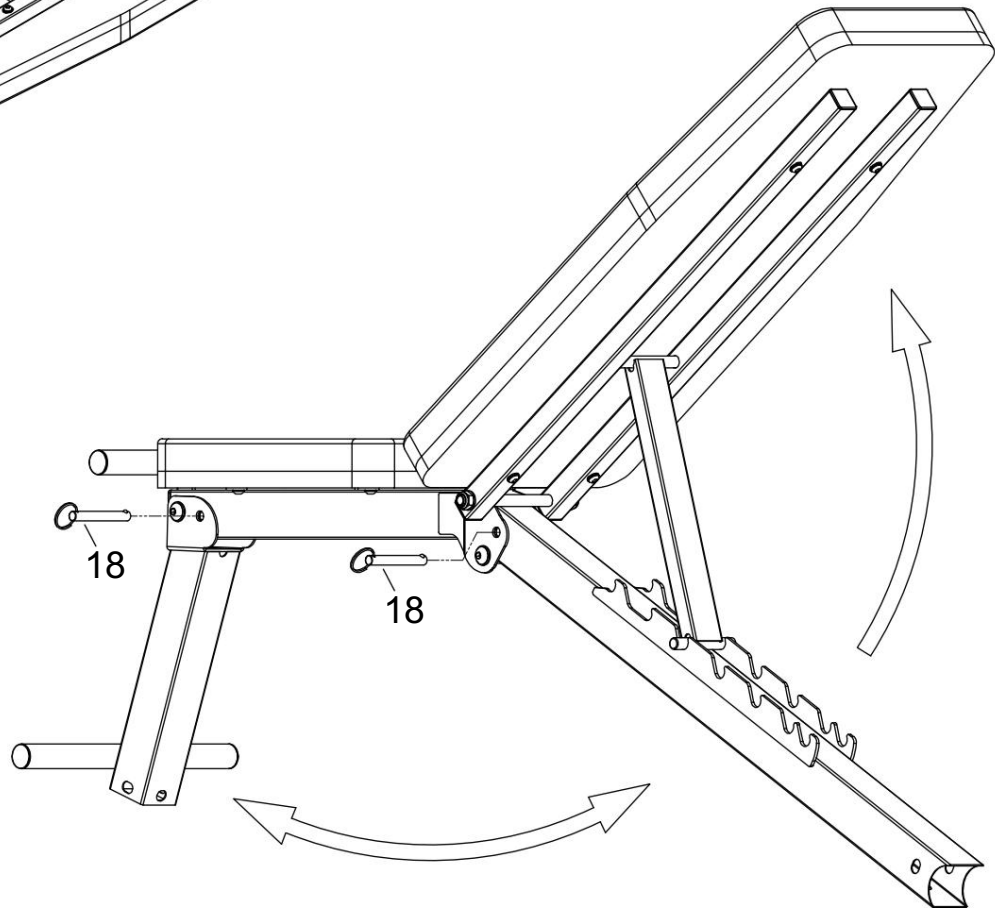
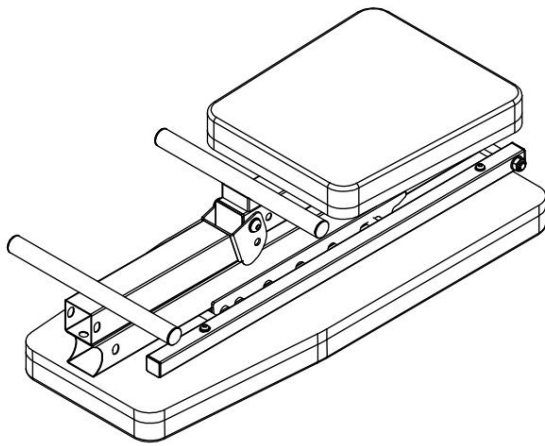

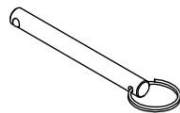

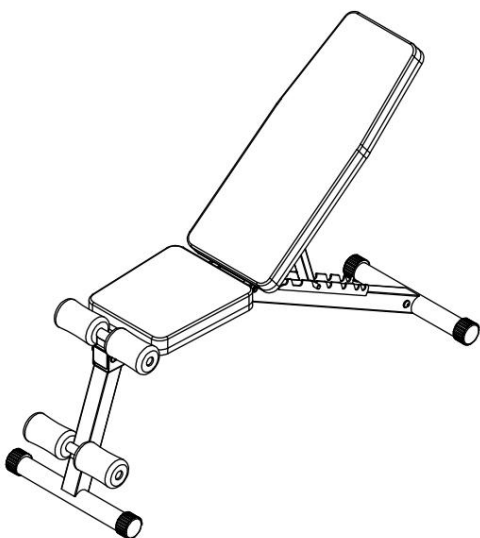
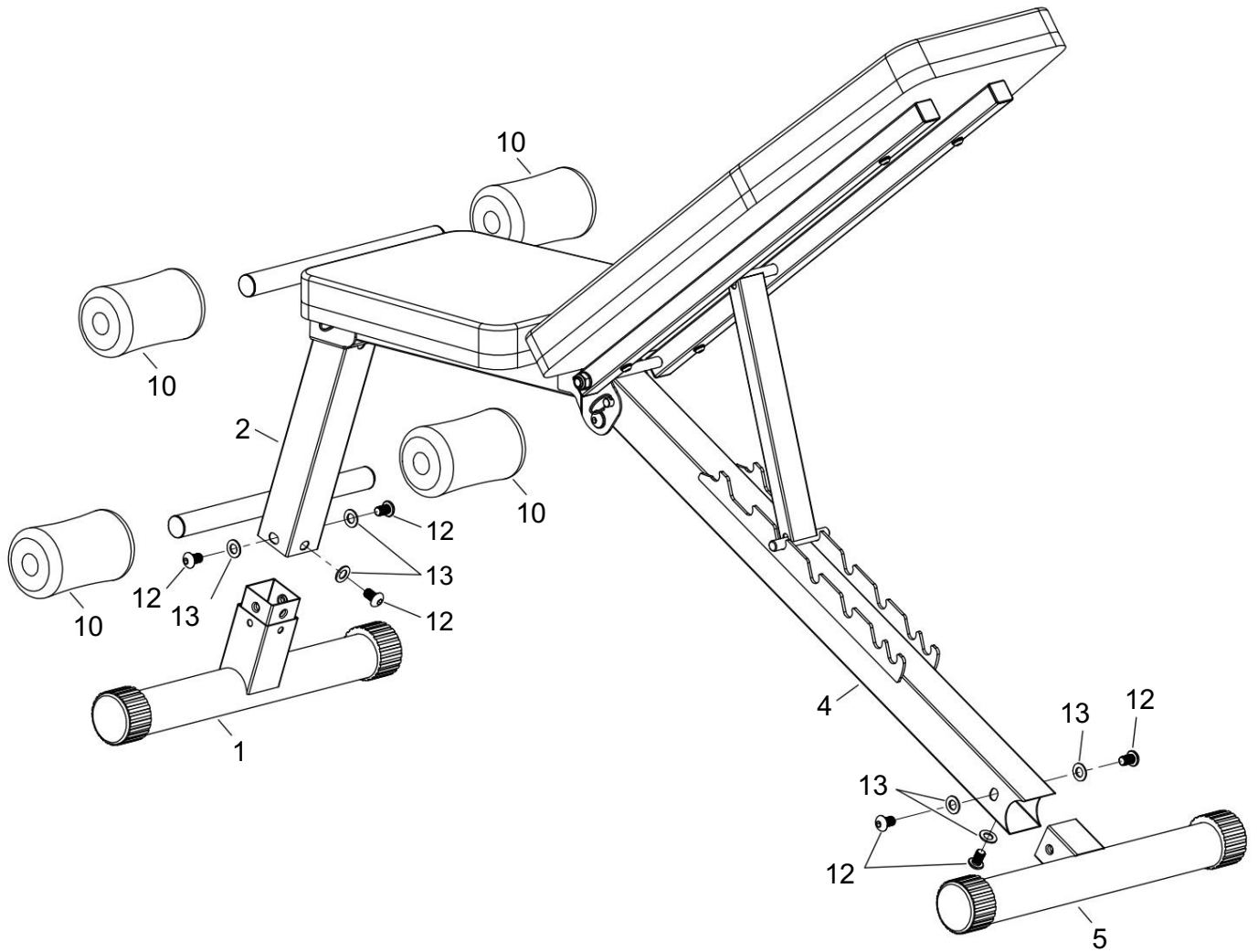

18#		CANTIDAD: 2
-----	---	-------------

INSTRUCCIONES DE MONTAJE

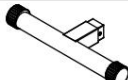
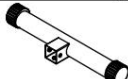
PASO 2:



1#		CANTIDAD: 1
5#		CANTIDAD: 1
10#		CANTIDAD: 4

12#		M10x15	CANTIDAD: 6
13#		M10	CANTIDAD: 6